

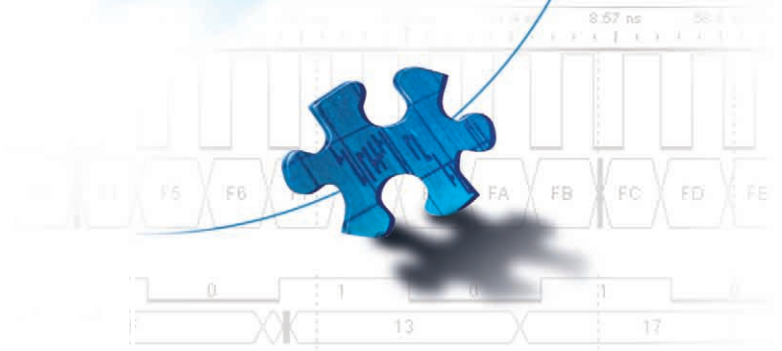

Getting There Just Got Easier



Agilent 1680 and 1690 Series Logic Analyzers
Solve critical digital design problems faster



Getting there just got easier

When you're debugging a design, you need to focus on solving your problems—not on mastering your debug tools. That's the thinking behind Agilent Technologies' new 1680 and 1690 series of logic analyzers. These instruments work intuitively, so you can answer critical design questions without first becoming an expert in measurement instruments.

You'll understand your logic analyzer right out of the box—thanks to the familiar Windows®-based features, the easy-to-navigate interface and the straightforward triggering. High performance doesn't mean difficult to operate. **Just turn the instrument on and you're ready to solve.**



Performance with Headroom

You get accurate and reliable measurements for today's processors and buses, with power to cover future technology trends:

- 200 MHz state
- Up to 800 MHz timing with 4 M of memory depth
- 200 MHz transitional timing

Instant Familiarity and Insights

The single-screen operation, intuitive triggering and familiar Windows interface provide answers quickly and easily—so you can focus on debugging your design.

Fitting Your Work Style

Small-footprint benchtop and PC-hosted models are available for integration into your debug environment. And offline analysis capabilities allow you to continue making measurements while you work at getting answers. These instruments work the way you work.



Windows Familiarity and Single-Screen Operation

A familiar Windows-based user interface takes the complexity out of making logic analyzer measurements. You'll feel right at home from the moment you turn on the instrument. And if you haven't used your logic analyzer in a while, you won't have to spend hours getting reacquainted with its features.

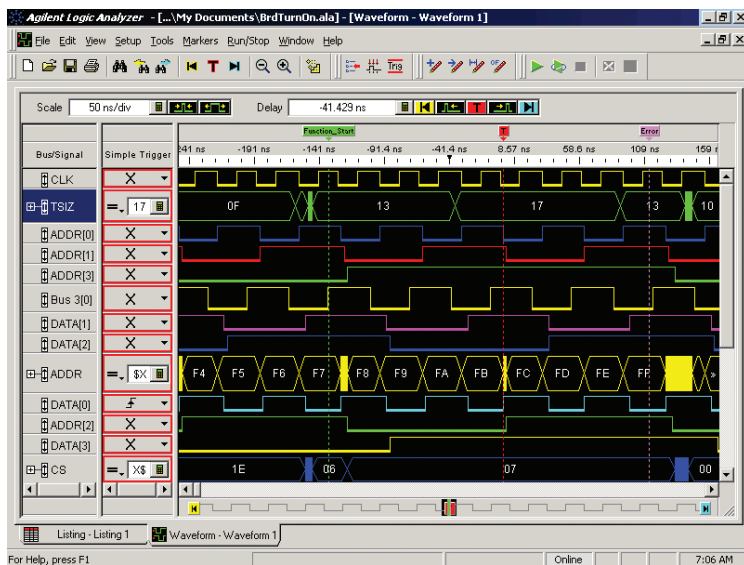

Perform all operations directly from the main screen—as you would with a PC application such as Microsoft® Word or Excel.

Access the most frequently used features via icons.

Select advanced features from the standard Windows menu bar.

Expand/compress buses with Windows-like +/- symbols.

Three measurement modes

State Analysis

State analysis uses a signal from your system under test to determine when to sample. Because state analysis samples are synchronous to the system under test, they provide a view of what your system is executing. You can capture microprocessor and bus cycles and then convert the data into processor mnemonics or bus transactions with inverse assemblers from Agilent or one of our third-party partners.

Timing Analysis

Timing analysis uses the logic analyzer's internal clock to determine when to sample system activity. With up to 800 MHz sampling and 4 M deep memory, you'll see the order of events with high resolution over a long period of time.

Transitional Timing

If your system has bursts of activity followed by times with little activity, you can use transitional timing to capture a longer period of system activity. In transitional timing, the analyzer samples data at regular intervals but stores the data only when there is a transition on one of the signals.

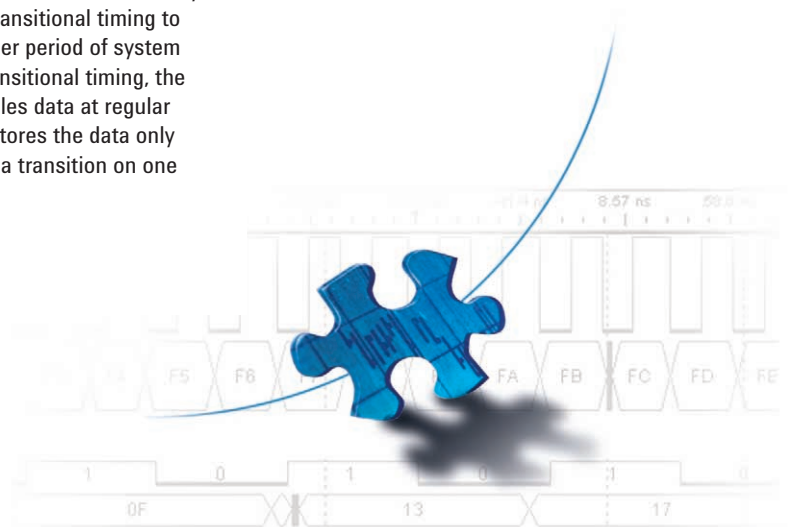



When you know what you want to capture,
trigger the way you think

During board turn-on and system debug, Agilent's straightforward triggering capabilities help you quickly narrow in on the root cause of a problem. You can capture every aspect of your design, from a simple stuck bit to the complex sequence of events leading up to a timing problem. The intuitive triggering helps you identify the cause of elusive problems in less time—so you can get to your solution quickly.

Selections for individual signals

- Rising Edge
- Falling Edge
- Either Edge
- High
- Low
- Don't Care
- Advanced Trigger...

Qualification selections for bus patterns

- Equals
- Not Equal To
- Less Than
- Greater Than
- Less Than Or Equal To
- Greater Than Or Equal To
- In Range
- Not In Range
- Advanced Trigger...

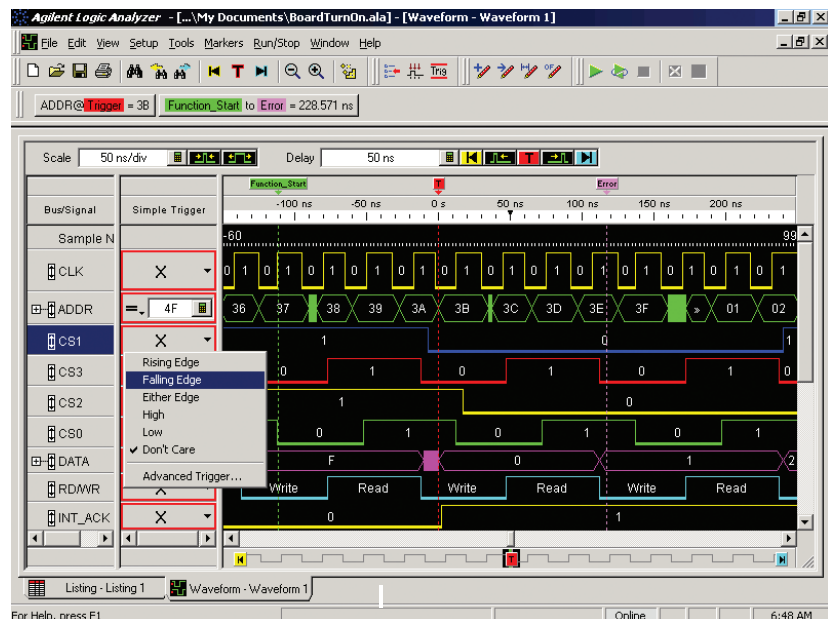

Simple Trigger

Set the trigger according to how you think about your target signals. Use standard events, such as rising edge, falling edge or pattern, to define a trigger event. These events are accessible via an easy pull-down menu.

You can set the trigger for an event on the basis of activity on one or more buses or signals. Simply select the patterns, edge or levels for the signals that apply.

- Zoom In
- Set Quick Trigger
- Find Next
- Find Previous

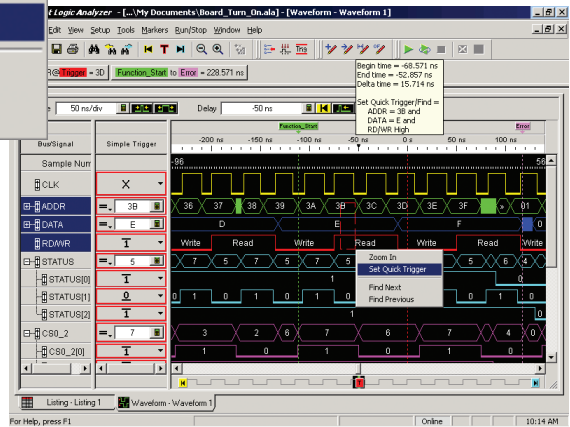

Set Quick Trigger

See something you didn't expect in the current trace? Simply draw a box around the questionable event and select Set Quick Trigger to see if it occurs again. You don't have to spend time defining the trigger. The instrument does the work for you.

- Edge
- Bus Pattern
- Other
- Advanced

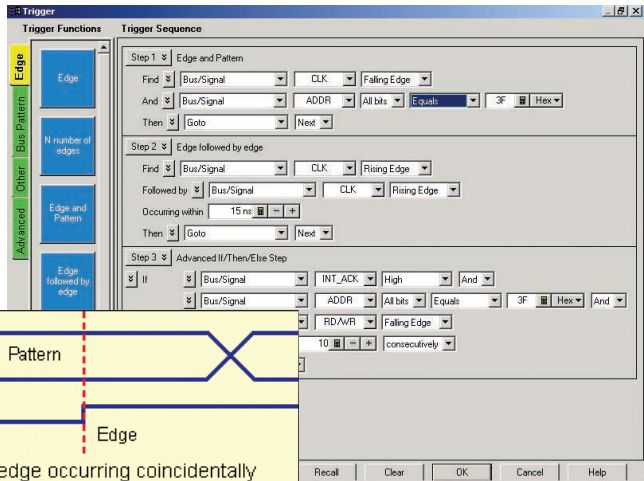

Find an edge occurring coincidentally with a bus pattern.

Advanced Trigger

With the Advanced Trigger, you can customize a trigger for your specific situation. You can use trigger functions as individual trigger events or as building blocks for complex scenarios.

Icons provide a graphical representation for each trigger function. Simply drag-and-drop an icon into the trigger sequence. To fully define the trace event, fill in the blanks with values or select standard options from the pull-down menu.

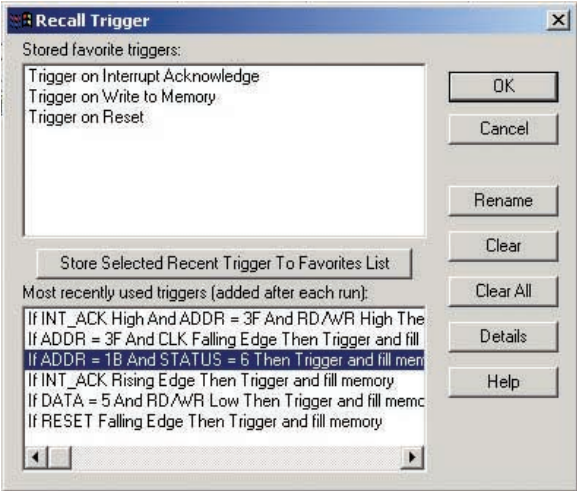

Trigger History/Recall

Save and name each trigger to create a series of your favorite triggers. Recall a previous trigger to test your latest defect fix. Have the confidence of knowing you can make the same measurement later without having to spend time setting up the instrument.

Benchtop 1680 series

Agilent's 1680 series benchtop logic analyzers feature a 12.1-inch color display and convenient knobs and hot keys. A glance at the interface provides quick insights on your measurements, as well as information on the status of the instrument.

The **12.1-inch color display** allows you to see more data. Viewing relationships between large amounts of signals and buses helps you identify a problem sooner.

Backlit LEDs show you the current logic analyzer settings at a glance.

Front panel knobs let you quickly change the vertical and position settings of the display. You can accurately place unlimited markers to make critical timing measurements.

Cable flexibility allows you to conveniently access your target from the front or back of the benchtop 1680 series.

A **Default Setup key** returns the logic analyzer to a known state—an important feature if you share your logic analyzer.

The **small footprint** saves valuable workspace.

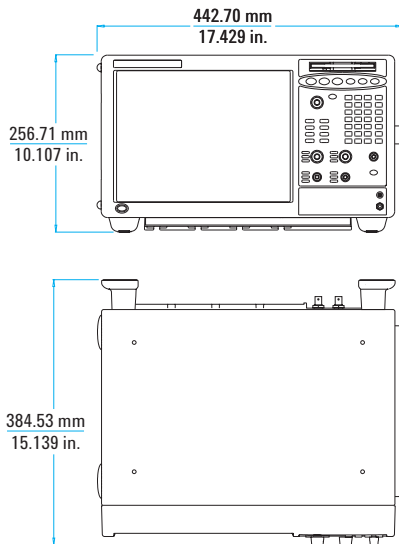

Back panel of the benchtop 1680 series

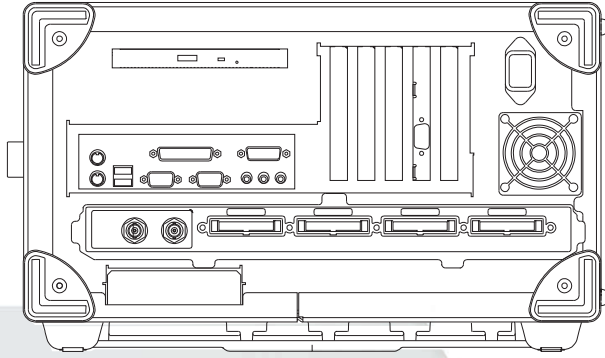

Connecting to your world

Each measurement you take provides additional clues to the cause of your design problems. Because access to your captured traces and the answers they provide is critical, your Agilent 1680 series benchtop logic analyzer gives you several options for data storage, retrieval and sharing.

A **10/100Base-T LAN interface** lets you easily print waveforms on networked printers, save your results on your office PC, and share information with others.

The **hard-drive capacity—15 GB minimum**—allows you to store all of your setups and results for future recall.

The **1.44 MB floppy drive** makes it easy to save your setups to standard 3.5-inch floppy disks.

Two IEEE 1394 ports enable connection of external hard drives or read/write CD-ROM drives for data storage and retrieval.

Two USB ports enable the hot connection of mouse or keyboards.

A **mouse** lets you point and click with ease, or you can choose a different pointing device that best meets your needs. A small keyboard is standard.

Trigger In/Trigger Out BNCs allow you to trigger or arm external devices and to receive signals that can be used to arm the logic analyzer.

A **parallel printer port** lets you print hard copies of screen graphics for project documentation.

An **external video port** allows you to connect large displays.

A **24x CD-ROM drive** is used to update system software.

PC-hosted 1690 series

Agilent's 1690 series PC-hosted logic analyzers provide the lowest price point for high-performance logic analysis. They allow you to carry out your debug work in your familiar PC environment.



An IEEE 1394 port provides direct connection to a 500 MHz minimum Intel® Celeron or AMD K-6 II (or equivalent) PC running Windows 2000 Professional. Purchase additional quantities of E5851A (IEEE 1394 PCI card and cable) so the instrument can be shared throughout the team.

PC-hosting allows you to see your design with the same display size and resolution of your regular working environment.

Trigger In/Trigger Out BNCs allow you to trigger or arm external devices and to receive signals that can be used to arm the logic analyzer.

Cables connect conveniently to your target from the front of the analyzer.

Access to your captured traces, your ability to store and retrieve data, and your print capabilities depend on your PC and network environment.

A smaller footprint saves valuable workspace and makes for easy portability.

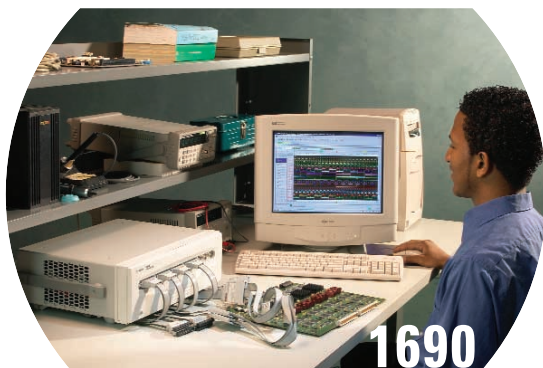
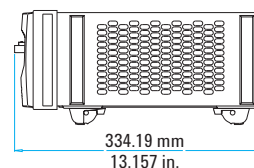
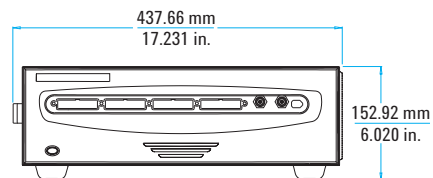

series - PC hosted

Get instant insights into your design

Your Agilent logic analyzer helps you expose problems quickly and easily, so you can spend your time designing a solution. The instrument's navigation, data view and analysis features provide instant insights into your system's operation.

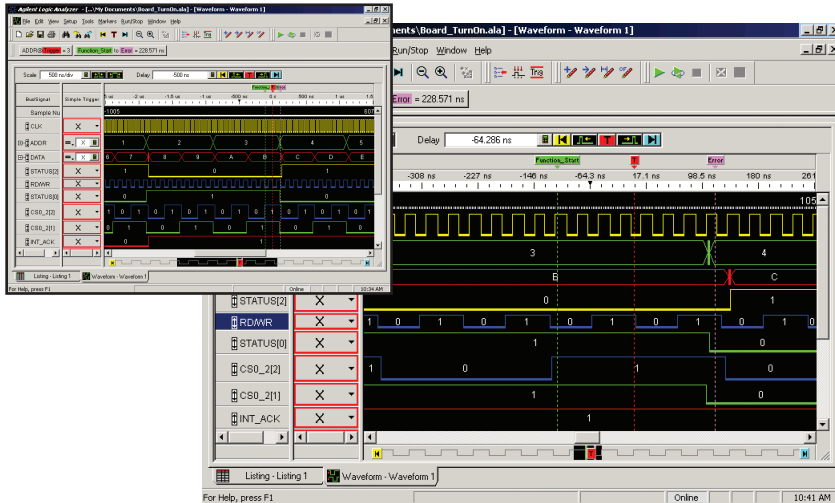

Trace Navigation

Traverse the trace quickly using Beginning, Trigger and End icons.

Scroll rapidly through the measurement using the dedicated knobs or GUI scroll bars.

Zoom in and out to get just the view you want.

Receive instant feedback on the exact position of the display data relative to the entire trace.

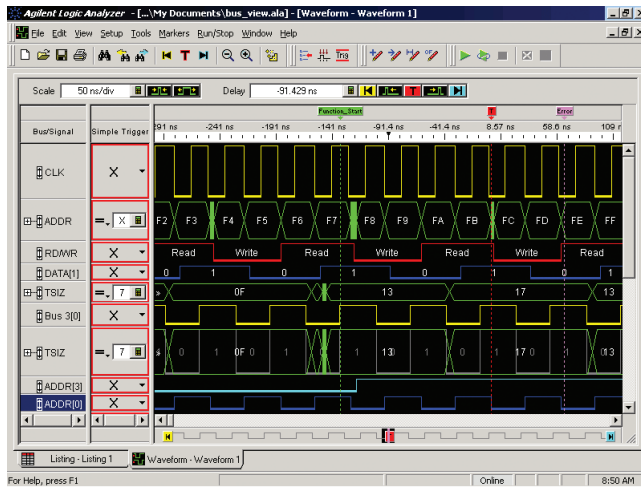

Data View

Check the activity indicators to see if your target is alive.

Individually color and size the signals/buses to highlight and differentiate areas of interest.

View data in a format you understand—binary, hex, decimal, ASCII, or user defined symbols.

Compare signals/buses directly with the Overlay feature.

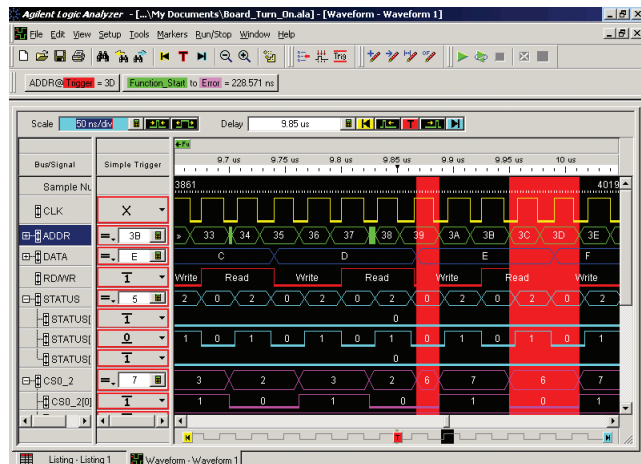

Analysis Tools

Find meaning in the most complex data with Find and Filter tools.

Gain quick insights into event frequency by using the color selection in the Filter tool.

Simultaneously view bus values and chart bus activity over time.

Specifications and Characteristics

Agilent Technologies
1680 and 1690 series

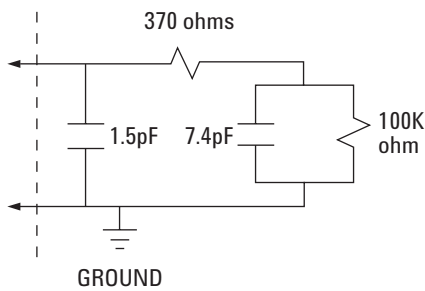

Equivalent Probe Load for the 01650-61608
General-Purpose Lead Set.

Channels	136, 102, 68, 34
State Analysis	
State speed	200 MHz
State memory depth	Standard: 256K Deep: 1M
Minimum state clock pulse width	1.2ns
Time tag resolution	4ns or +/-0.1%, whichever is greater
Maximum time count between states	17 seconds
State clock/qualifiers	4 (2 on 34 channel models)
Minimum master-to-master clock time	5.0 ns
Minimum master-to-slave clock time	2.0 ns
Minimum slave-to-master clock time	5.0 ns
Setup/hold time (Single clock, single edge)	2.5 ns window adjustable from 4.5/-2 ns to -2.0/4.5 ns in 100 ps increments per channel
Setup/hold time (Multiple clock, multi edge)	3.0 ns window adjustable from 5.0/-2 ns to -1.5/4.5 ns in 100 ps increments per channel
Timing Analysis	
Timing speed	400/800 MHz (full/half channel)
Timing memory depth	Standard: 512K/1M (full/half channel) Deep: 2M/4M (full/half channel)
Sample period, full channels	2.5 ns to 1 ms
Sample period, half channels	1.25 ns
Sample period accuracy	+/- (0.01% of Sample period +/- 100 ps)
Channel-to-channel skew	<1.5ns typical
Time interval accuracy	+/- (Sample period accuracy + channel-to-channel skew +0.01% of reading)
Triggering	
Sequencer speed	200 MHz
Maximum occurrence counter	16,777,215
Range width	32 bits
Timer value range	100 ns to 5497 seconds
Timer resolution	5 ns
Timer accuracy	10 ns +/-0.01% of setting
Trigger resources	16 patterns 15 ranges
Timers	3 (136 channels) 2 (102 channels) 1 (68 channels) 0 (34 channels)
Occurrence counters	1 per sequence level
Trigger sequence levels	16
Trigger in arms logic analyzer	15 ns typical delay
Trigger to Trigger out	150 ns typical delay
Probes	
Input resistance	100 K Ohms +/- 2%
Parasitic tip capacitance	1.5 pf
Maximum input voltage	+/- 40V peak
Minimum voltage swing	500 mV p-p
Threshold range	-6V to + 6V in 10 mV increments
Threshold accuracy	+/- (65mV + 1.5% of setting)

A family of high performance logic analyzers at an affordable price

Agilent's Windows-based logic analyzers are designed to match your work style, application and budget. In all, 16 models offer a variety of channel counts and memory depths in benchtop or PC-hosted form factors. Each provides the same performance, core features and functionality in a small footprint that saves valuable workspace.

Measurement Modes	Memory Depths
State: 200 MHz	Standard: 256 K Deep: 1 M
Timing: 400/800 MHz (full/half channel)	Standard: 512 K/1 M (full/half channel) Deep: 2 M/4 M (full/half channel)
Transitional Timing: 200 MHz	Standard: 256 K Deep: 1 M

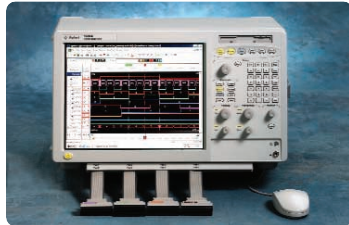

1680 series

- Self-contained benchtop instrument
- Large, built-in, 12.1-inch color display
- Cable flexibility—front or back
- Front panel knobs and hot keys
- Includes a mouse, mini keyboard, front panel cover and accessory pouch



1690 series

- PC-hosted instrument
- Uses PC display
- Cable connection from the front
- Small footprint, lowest price
- Includes desktop IEEE 1394 PCI card and cable, laptop IEEE 1394 cable and accessory pouch

Selecting a logic analyzer to meet your application and budget is as easy as 1, 2, 3

	1 Choose the form factor	2 Choose the memory depth	3 Select the channel count			
			136 Channels	102 Channels	68 Channels	34 Channels
Benchtop 1680 Series		Standard Memory	1680A	1681A	1682A	1683A
		Deep Memory	1680AD	1681AD	1682AD	1683AD
PC-Hosted 1690 Series		Standard Memory	1690A	1691A	1692A	1693A
		Deep Memory	1690AD	1691AD	1692AD	1693AD

Solve critical digital design problems faster.



Get there today:
www.agilent.com/find/digitaldesign

Create a quality connection to your target system

Agilent provides probing solutions that deliver a solid electrical and mechanical connection to your target, no matter what mix of chip packages, test ports and probes your application requires. The 1680 and 1690 series logic analyzers also provide inverse assembly support for many of today's leading processors and buses.

The following literature provides information on probing and specific processor/bus solutions for the 1680 and 1690 series analyzers. For copies of this literature, contact your Agilent representative or visit: www.agilent.com/find/digitaldesign

Publication	Description	Agilent Pub. Number
Probing Solutions for Agilent Logic Analysis Systems	Product Overview	5968-4632E
Processor and Bus Support for Agilent Technologies Logic Analyzers	Configuration Guide	5966-4365E

Agilent Technologies' Test and Measurement Support, Services, and Assistance

Agilent Technologies aims to maximize the value you receive, while minimizing your risk and problems. We strive to ensure that you get the test and measurement capabilities you paid for and obtain the support you need. Our extensive support resources and services can help you choose the right Agilent products for your applications and apply them successfully. Every instrument and system we sell has a global warranty. Support is available for at least five years beyond the production life of the product. Two concepts underlie Agilent's overall support policy: "Our Promise" and "Your Advantage."

Our Promise

Our Promise means your Agilent test and measurement equipment will meet its advertised performance and functionality. When you are choosing new equipment, we will help you with product information, including realistic performance specifications and practical recommendations from experienced test engineers. When you use Agilent equipment, we can verify that it works properly, help with product operation, and provide basic measurement assistance for the use of specified capabilities, at no extra cost upon request. Many self-help tools are available.

Your Advantage

Your Advantage means that Agilent offers a wide range of additional expert test and measurement services, which you can purchase according to your unique technical and business needs. Solve problems efficiently and gain a competitive edge by contracting with us for calibration, extra-cost upgrades, out-of-warranty repairs, and on-site education and training, as well as design, system integration, project management, and other professional engineering services. Experienced Agilent engineers and technicians worldwide can help you maximize your productivity, optimize the return on investment of your Agilent instruments and systems, and obtain dependable measurement accuracy for the life of those products.

For more assistance with your test and measurement needs or to find your local Agilent office go to

www.agilent.com/find/assist

Product specifications and descriptions in this document subject to change without notice.

© Agilent Technologies, Inc. 2001

Printed in USA June 29, 2001

Intel is a U.S. registered trademark and Celeron is a U.S. trademark of Intel Corporation. Microsoft and Windows are U.S. registered trademarks of Microsoft Corporation.

5988-2675EN



Agilent Technologies